

**OPERATING AND MAINTENANCE MANUAL FOR ULTRALIGHT AEROPLANE  
Samba XXL**

**1. GENERAL**

*1.1. Record of Revisions*

**1.2. *List of Effective Pages***

**OPERATING AND MAINTENANCE MANUAL FOR ULTRALIGHT AEROPLANE**  
**Samba XXL**

**1.3. Table of contents**

<b>1. GENERAL.....</b>	<b>1-1</b>
1.1. RECORD OF REVISIONS.....	1-1
1.2. LIST OF EFFECTIVE PAGES .....	1-2
1.3. TABLE OF CONTENTS.....	1-3
<b>2. TECHNICAL DATA .....</b>	<b>2-1</b>
2.1. BASIC TECHNICAL DATA .....	2-1
2.1.1. <i>Basic Dimensions Samba XXL</i> .....	2-1
2.1.2. <i>Engine</i> .....	2-2
2.2. THREE VIEW DRAWING.....	2-4
2.3. TECHNICAL DESCRIPTION OF THE AIRPLANE.....	2-5
2.3.1. <i>Fuselage</i> .....	2-5
2.3.2. <i>Wing</i> .....	2-5
2.3.3. <i>Horizontal tail unit ( HTU )</i> .....	2-5
2.3.4. <i>Vertical tail unit ( VTU )</i> .....	2-5
2.3.5. <i>Control system</i> .....	2-6
2.3.6. <i>Landing gear</i> .....	2-7
2.3.7. <i>Power plant control</i> .....	2-8
2.3.8. <i>Fuel system</i> .....	2-8
2.3.9. <i>Electrical system</i> .....	2-9
2.3.10. <i>Pittot-static system</i> .....	2-11
2.3.11. <i>Equipment</i> .....	2-12
2.3.12. <i>Instrument panel</i> .....	2-13
2.3.13. <i>Interior &amp; exterior placards</i> .....	2-14
<b>3. PERIODICAL INSPECTIONS AND INTERVALS.....</b>	<b>3-1</b>
3.1. PRE-FLIGHT INSPECTION.....	3-1
3.2. PERIODICAL INSPECTION INTERVALS.....	3-1
3.2.1. <i>Periodical inspections Sign off sheets</i> .....	3-1
3.2.2. <i>Periodical inspection after the first 25 hours and every 50 hours</i> .....	3-2
3.2.3. <i>Periodical inspection after every 100 flight hours</i> .....	3-3
<b>4. OPERATION AND MAINTENANCE .....</b>	<b>4-1</b>
4.1. OUTLINES.....	4-1
4.2. WEIGHT AND CENTER OF GRAVITY POSITION .....	4-1
4.2.1. <i>Empty weight determination</i> .....	4-1
4.2.2. <i>Operating C.G. range calculation</i> .....	4-1
4.3. MECHANISM ADJUSTMENTS .....	4-2
4.3.1. <i>Torque moments</i> .....	4-2
4.3.2. <i>Control Surface Deflections</i> .....	4-3
4.4. PERMISSIBLE TOLERANCES ( PLAYS).....	4-4
4.5. LUBRICATING CHART .....	4-5
4.5.1. <i>Recommended lubricants</i> .....	4-5
4.5.2. <i>Airframe lubrication fundamentals</i> .....	4-5
4.6. BRAKE FLUID REFILLING, BRAKE SYSTEM BLEEDING, BRAKE PAD CLEARANCE ADJUSTMENT.....	4-6
4.6.1. <i>Brake fluid refilling</i> .....	4-6
4.6.2. <i>Brake system bleeding</i> .....	4-6
4.6.3. <i>Brake pad clearance adjustment</i> .....	4-6
4.6.4. <i>Brake pad replacement</i> .....	4-6
4.7. GROUND HANDLING .....	4-7
4.7.1. <i>Towing the airplane</i> .....	4-7
4.7.2. <i>Parking the airplane</i> .....	4-7
4.7.3. <i>Tieing-down</i> .....	4-7
4.7.4. <i>Jacking the airplane</i> .....	4-7
4.7.5. <i>Road transport</i> .....	4-8
4.8. CLEANING AND CARE .....	4-9

**OPERATING AND MAINTENANCE MANUAL FOR ULTRALIGHT AEROPLANE**  
**Samba XXL**

4.8.1.	<i>Airplane care outlines</i> .....	4-9
4.8.2.	<i>External surfaces cleaning</i> .....	4-9
4.8.3.	<i>Interior cleaning</i> .....	4-9
4.8.4.	<i>Cockpit canopy cleaning</i> .....	4-9
4.9.	AIRPLANE DISASSEMBLY.....	4-10
4.9.1.	<i>Wing disassembly</i> .....	4-10
4.9.2.	<i>Wing assembly</i> .....	4-10
4.9.3.	<i>HTU disassembly</i> .....	4-10
1.	Rematch the safety pin and unscrew the M8 screw.....	4-10
4.9.4.	<i>HTU assembly</i> .....	4-10
<b>5.</b>	<b>REPAIRS</b> .....	<b>5-1</b>
5.1.	DAMAGE CLASSIFICATION.....	5-1
5.2.	RUDDER CONTROL CABLES REPLACEMENT.....	5-1
5.3.	FIBREGLASS FAIRING AND COWLINGS REPAIRS.....	5-1
<b>6.</b>	<b>APPENDICES</b> .....	<b>6-1</b>

**OPERATING AND MAINTENANCE MANUAL FOR ULTRALIGHT AEROPLANE**  
**Samba XXL**

**2. TECHNICAL DATA**

**2.1. Basic technical data**

**2.1.1. Basic Dimensions** **Samba XXL**

Wing

span .....	10 m
area .....	8,9 m <sup>2</sup>
MAC .....	0,89 m
loading .....	50,56 kg/m <sup>2</sup>

Aileron

area .....	0,173 m <sup>2</sup>	-
------------	----------------------	---

Flap

area .....	0,707 m <sup>2</sup>	-
------------	----------------------	---

Fuselage

length .....	6,15 m
with .....	1,12 m
height .....	2,20 m

Horizontal Tail Unit (HTU)

span .....	2,5 m
area .....	1,36 m <sup>2</sup>
elevator area .....	0,5 m <sup>2</sup>

Vertical Tail Unit (VTU)

height .....	0,94 m
area .....	0,76 m <sup>2</sup>
rudder area .....	0,32 m <sup>2</sup>

Landing Gear

main wheel diam./width .....	0,4 m/0,1 m
nose wheel diam./width .....	0,3 m/0,1 m

**OPERATING AND MAINTENANCE MANUAL FOR ULTRALIGHT AEROPLANE  
Samba XXL**

*2.1.2. Engine*

Engine

The ROTAX 912 ULS is 4-stroke, 4 cylinder, horizontally opposed, spark ignition machine, one central camshaft – push – rods – OHV. Liquid cooled cylinder heads, ram air cooled cylinder. Dry sump forced lubrication. Dual breaker less capacitor discharge ignition.

Engine electrical system consist of 10-poles single –phase generator, ignition, electric starter, regulator and 12 V battery. The coolant is forced through the radiator by a water pump, driven from the crankshaft to cylinder heads. From the top of cylinder heads the coolant passes on the expansion tank which allows for coolant expansion. The expansion tank is closed by a pressure cap with excess pressure valve and return valve. When the temperature rises the coolant creating excess pressure, a relief valve opens and the coolant flows through a hose to the overflow bottle mounted on the firewall.

The engine is attached to the engine mount attached to the firewall with 4 bolts. The engine mount is spring – mounted with 4 rubber shock absorber.

Engine Manufacturer..... Bombardier – Rotax GmbH Gurnskirchen, Austria.

The TL engine instrument displays the following parameters:

- Engine rpm
- Engine hours
- Exhaust gases temperature
- Cylinder head temperature
- Oil temperature
- Oil pressure
- Overrun of data limits

**OPERATING AND MAINTENANCE MANUAL FOR ULTRALIGHT AEROPLANE  
Samba XXL**

*Engine Technical Data*

Power

Max Take off power.....70 kW / 95 hp at 5800 rpm max. 5 min  
Max. Continuous power.....69 kW / 93,84 hp at 5500 rpm  
Cruising power.....44,6 kW / 60 hp at 4800 rpm  
Idling rpm.....1400 rpm

Cylinder Heat Temperature

Maximum..... 150 °C

Oil Temperature

Minimum .....50 °C  
Maximum..... 140 °C  
Optimum Operating ..... 90-110 °C

Fuel Pressure

Maximum..... 0.4 bar  
Minimum ..... 0.15 bar

Fuel brands

- Automotive premium grade petrol, according to DIN 516000,Ö-NORM C 1103
- EUROSUPER RON 95 unleaded accord. to DIN 51607,Ö-NORM 1100
- AVGAS 100 LL
- the BA 95 NATURAL is recommended for the Czech Republic

Oil brands

Automotive engine oil of registered brand with gear additives, but not aircraft oil API classification “SF” or “SG”

Fuel consumption

Max. Take off power .....22.7 l / h  
Cruising power 75 % ..... 16.2 l / hod  
Specific. consumption..... 285 g / kWh

Propeller

2 blade, fixed.....Ø 1.7 m  
pitch 0.75 R..... adjustable

manufacturer ..... WOODCOMP

**OPERATING AND MAINTENANCE MANUAL FOR ULTRALIGHT AEROPLANE  
Samba XXL**

**2.2. Three view drawing**

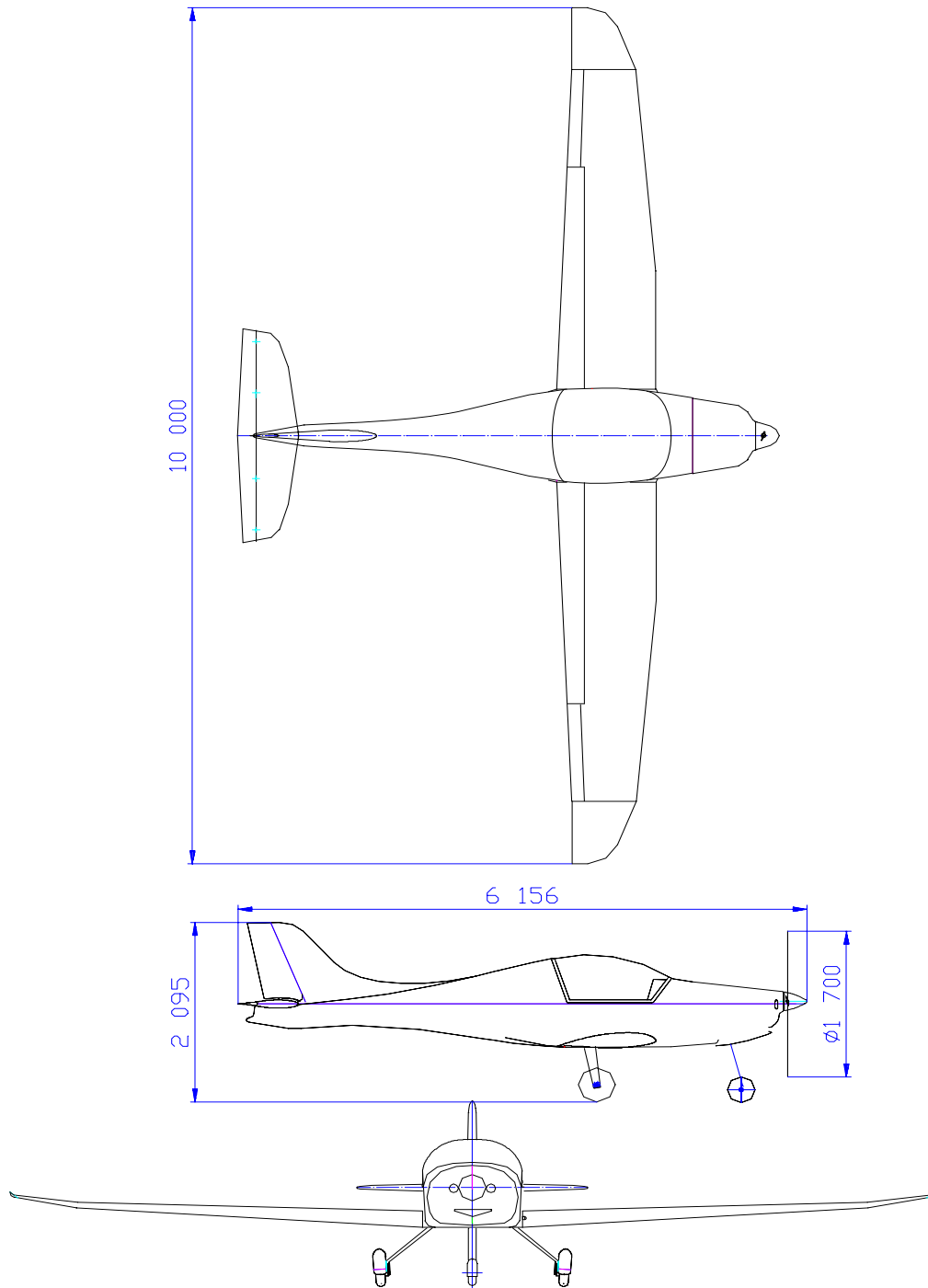



**OPERATING AND MAINTENANCE MANUAL FOR ULTRALIGHT AEROPLANE**  
**Samba XXL**

**2.3. Technical description of the airplane**

**2.3.1. Fuselage**

The fuselage is all – carbon/kevlar monocoque construction. Safety belts are attached to the seats and to a shelf for lightweight objects (headphones, maps, etc.) The engine is attached to the firewall covered with the fire resistant mat. The removable engine cowling is attached with 14 screws. The cockpit canopy is made of the Perspex of 3 mm thickness. The canopy may be tilted backwards. Two side sliding windows and the windshield air window are installed on the canopy to vent the cockpit.

An instrument panel is attached to the cockpit front part. There are installed the flight, engine instruments, switches, fuses and throttle lever on the instrument panel.

The wing center-section is formed with the two bushings for wing connecting pins.

The hand control system rods are connected by means of the automatic grips installed on the wings center – section ribs.

The fuselage main spar is located between the seats. The nose wheel and rudder pedals are attached to the main spar front part.

The main landing gear leg bracket is attached to the fuselage main spar rear part. The flap control lever bearing is located on the upper side of the fuselage main spar.

The vertical tail unit is of sandwich construction. The horizontal tail unit is attached to the VTU front part with the two pins and the one screw.

The rudder is controlled by the two cables. The ailerons, flaps and elevator are controlled through rods. The cockpit heating is done through the two holes located in the firewall cower part to bring the hot to the cockpit.

**2.3.2. Wing**

The cantilever wing is a monospar construction with the sandwich skin consist of the two fiberglass layers and the special foam core. The spar flanges are made from a carbon Fibers. The spar web is the sandwich construction, also. The wing root ribs are stuck between the spar flanges. The wing pins, bushings, control system nuts and fuel level float bracket are laminated to the root rib. The 50 liters fuel tank is an integral part of the wing.

**2.3.3. Horizontal tail unit ( HTU )**

The HTU is of the some construction as the wing, only the spar is made from the carbon fiber.

**2.3.4. Vertical tail unit ( VTU )**

The VTU is of the some construction.

**OPERATING AND MAINTENANCE MANUAL FOR ULTRALIGHT AEROPLANE  
Samba XXL**

*2.3.5. Control system*

The airplane is equipped with a classic dual control system. The elevator and ailerons are controlled by a control sticks, connecting rods and arms. The longitudinal control system stops are attached to the seats. The lateral control system stops are located on the control sticks. There is the twisting spring controlled by lever next to the control stick to trim a force in the longitudinal control system.

The wing flaps are controlled a control lever between a seats. The lever is in a changing gate and welded to a torsion tube. There are the levers and rods at both ends of torsion tube to control the flaps. The rudder control system is dual too. The rudder is controlled by cables attached at the rudder pedals and to the hinges on the rudder bottom rib. There are the two turn buckles to adjust the length of the cables.

The rudder control is connected by the rods to the nose wheel steering arms.

The rudder cables are crossed between the pedal- and the rudder connections, that means, the cable connected to the right pedal is connected to the left side of the rudder.

**OPERATING AND MAINTENANCE MANUAL FOR ULTRALIGHT AEROPLANE**  
**Samba XXL**

*2.3.6. Landing gear*

The airplane is equipped with fixed nose wheel landing gear. The nose wheel is controllable. The main wheels on both legs are equipped with hydraulic brakes. There is the brake level on the pilot's control stick. The main legs are formed from fiberglass springs. The main wheels of 400x100 mm size consists of a duralumin alloy rim, bearings and duralumin brake disc. The brake caliper with the one hydraulic cylinder is floating. There is a brake fluid hose connected to the brake caliper to the master cylinder on the control stick. The nose wheel leg is formed from high quality steel tubes welded together. There is a rubber shock absorber to spring the leg.

The nose wheel steering is connected to the rudder control. The nose wheel has two ball bearings.

**OPERATING AND MAINTENANCE MANUAL FOR ULTRALIGHT AEROPLANE  
Samba XXL**

*2.3.7. Power plant control*

The engine power is controlled by a throttle lever located on the instrument panel, in the panel center line. There are the two bowden cables led from the throttle lever to the carburetors.

To start could engine the carburetors are equipped with a chords controlled by a lever located below the instrument panel. The ignition switches are located on the instrument panel. Switch on the ignition and the turn key in the in the switch box to start the engine.

*2.3.8. Fuel system*

The airplane is equipped with the two 50 liters fuel tank located in the wings.

The fuel tank filler neck is placed on the wing upper surface and equipped with a cap sealed by a packing "O" ring. A fuel tank bleeding hole is located on the wing tip. A fuel tank draining valve is located under the wing in the lowest part of the fuel tank. Use the valve to empty the fuel tank, also.

Fuel is puled in the fuel tank through the fuel tank outlet coarse screen. Then through the fuel valve and fine screen to the fuel pump and on he carburetors. Fuel quantity is indicated by an automotive fuel gauge located on the instrument panel. There is installed a float in the fuel tank to scan a fuel quantity. The fuel gauge displays the relative quantity of fuel inside the fuel tank, corresponding fuel quantity liters is shown on the placard "WEIGHT" in the cockpit.

*2.3.9. Electrical system*

The electrical system is single-wire type with negative side connected to the chassis. The power source is a single-phase generator (250 W) with a rectifier and 12 V/14 Ah battery. Separate appliances have separate switches. The circuits of the particular sections are guarded individually by fuses. The dual ignition is a separate part of the electrical system. Each ignition circuit has its own ON/OFF switch.

Wiring diagram No.1

**OPERATING AND MAINTENANCE MANUAL FOR ULTRALIGHT AEROPLANE**  
**Samba XXL**

Intentionally left blank for optional appliances wiring diagram

**OPERATING AND MAINTENANCE MANUAL FOR ULTRALIGHT AEROPLANE**  
**Samba XXL**

*2.3.10. Pittot-static system*

The pittot tube provides the ram air pressure to the airspeed indicator. The tube is on the fin tip. Pressure distribution to individual instruments is done through flexible plastic hoses. Keep the system deck to assure its correct function. If water gets inside the system disconnect hoses from the instruments and slightly blow into the system.

**WARNING!**

Do not blow into the system when the instruments are not disconnected - it may cause instruments damage.

# OPERATING AND MAINTENANCE MANUAL FOR ULTRALIGHT AEROPLANE Samba XXL

## 2.3.11. Equipment

### Standard equipment

The flight and engine instruments, COMM/NAV instruments, electrical appliances, switches, switch box, fuses, fuel valve and fuel gauge are on the instrumental panel. Optional instruments may be installed, also.

The seats are integral part of fuselage. The seats are thin-polstred by the soft removable upholstery. The headphones jacks are located aside the seats

Each seat is equipped with a four-part safety belts.

Position lights, anti collision lights and possible additional equipment optional.

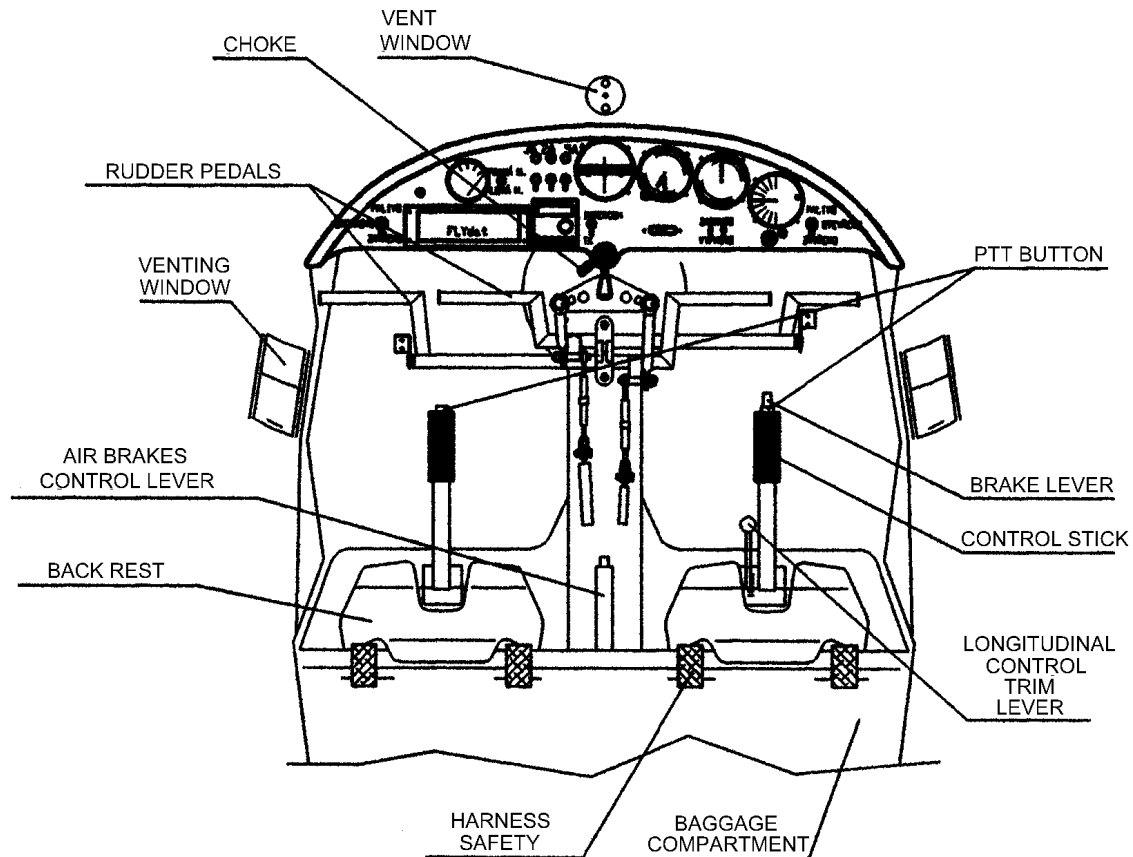

The following optional equipment is installed in the Samba XXL airplane

- Cockpit heating
- Wheel pants



## OPERATING AND MAINTENANCE MANUAL FOR ULTRALIGHT AEROPLANE Samba XXL

### 2.3.12. Instrument panel

The following instrument panel is installed in the Samba XXL airplane.

#### CAUTION

The owner (aircraft operating agency) of the airplane is responsible for placards readability during airplane service life.

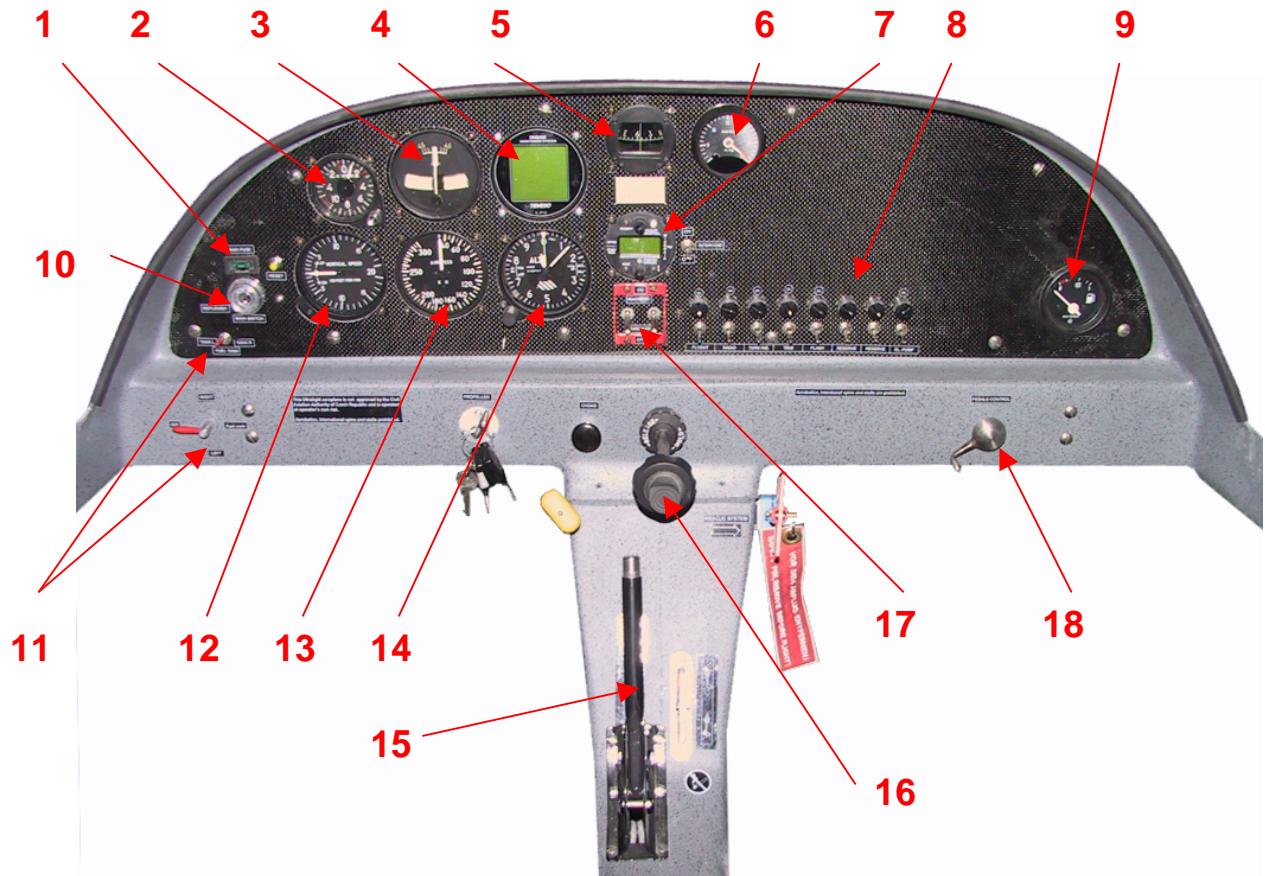

- |          |                      |           |                       |
|----------|----------------------|-----------|-----------------------|
| <b>1</b> | Main fuse            | <b>10</b> | Main key              |
| <b>2</b> | G-meter              | <b>11</b> | Fuel valve and switch |
| <b>3</b> | Turn indicator       | <b>12</b> | Vario                 |
| <b>4</b> | TL-engine instrument | <b>13</b> | Air speed indicator   |
| <b>5</b> | Compass              | <b>14</b> | Altimeter             |
| <b>6</b> | Burst meter          | <b>15</b> | Flaps control         |
| <b>7</b> | Radio                | <b>16</b> | Throttle              |
| <b>8</b> | Fuses and switches   | <b>17</b> | Magnetos              |
| <b>9</b> | Fuel indicator       | <b>18</b> | Pedals adjustment     |

**OPERATING AND MAINTENANCE MANUAL FOR ULTRALIGHT AEROPLANE  
Samba XXL**

*2.3.13. Interior & exterior placards*

**CAUTION:**

The owner (aircraft operating agency) of the airplane is responsible for placards readability during airplane service life.

<b>Samba XXL OK-IUA 54</b>	<b>URBAN – AIR</b>
<b>Empty weight</b>	<b>284.0 kg</b>
<b>MTOW</b>	<b>472.5 kg</b>
<b>Min. pilot weight</b>	<b>65.0 kg</b>
<b>Max. weight of baggage</b>	<b>4.0 kg</b>
<b>Max. speed</b>	<b>Vne 270 km/h</b>
<b>Max. speed with flaps</b>	<b>Vfe 110 km/h</b>
<b>Stall speed</b>	<b>Vso 65 km/h</b>

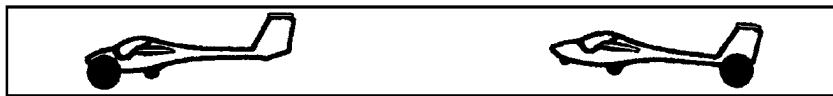

**Max. weight of crew if....**

<b>½ fuel tank (50 l)</b>	<b>153 kg</b>
<b>full fuel tank (100 l)</b>	<b>117 kg</b>
<b>half hour flight</b>	<b>181 kg</b>

### **3. PERIODICAL INSPECTIONS AND INTERVALS**

#### **3.1. *Pre-flight inspection***

Refer to the flight manual

#### **3.2. *Periodical inspection intervals***

The safety of operation and airplane airworthiness depend on a thorough care for the all parts of your airplane.

The periods for overall checks and contingent maintenance will depend on the conditions of de operations and the overall conditions of the airplane.

The manufacture recommends maintenance checks and periodic inspections in the following periods:

- a) after the first  $25 \pm 2$  flight hours
- b) after every  $50 \pm 3$  flight hours
- c) after every  $100 \pm 5$  flight hours or annual inspection at least

Refer to the Engine Manual for engine maintenance.

The propeller is maintained according to its condition. The inspection performed by the propeller manufacturer is highly recommended after 50 hours of operation.

##### **3.2.1. *Periodical inspections Sign off sheets***

The following Periodical maintenance Sign off sheets are intended for copying and serve as the maintenance Records. It is also recommended to include small repairs, damages and their remedy or replacement.

**OPERATING AND MAINTENANCE MANUAL FOR ULTRALIGHT AEROPLANE  
Samba XXL**

*3.2.2. Periodical inspection after the first 25 hours and every 50 hours*

Model :	S/N :	Registration :	Date of inspection :
	Hours flown :	No of Takeoffs :	

Event	Event description	Remark	Carried out by	Inspected by
1	Check control system for condition, plays, check control cables tension. Check control and securing of parts of the nose wheel steering (inside the cockpit)			
2	Check condition and attachment of controls inside cockpit			
3	Check condition and attachment of the seats back rests and safety belts incl. upholstery			
4	Check function of instruments			
5	Visually check canopy conditions. Check function of the struts of canopy			
6	Check wing, fuselage and tail surfaces skin			
7	Check condition and attachment of the canopy			
8	Check control surfaces condition, free movement and plays			
9	Check condition and attachment of the landing gear			
10	Check of the wheel braces			
11	Visually check condition, attachment, security of attachment bolts: engine – engine mount, engine mount – firewall. Visually check condition and integrity wires. Charge battery if needed			
12	Visually check of carburetors, air filters. Check engine controls adjustment			
13	Visually check condition, integrity of the fuel system and fuel tank draining			
14	Visually check of exhaust system and heating for condition, cracks			
15	Check prop attachment, security of bolts			
16	Check operating fluids quantity. Add if needed			
17	Clean the cockpit			
18	Lubricate the airplane per lubricating chart			
19	Engine Test Run			

**OPERATING AND MAINTENANCE MANUAL FOR ULTRALIGHT AEROPLANE  
Samba XXL**

20	Check Ground Cable – Engine, Fuel Tank and Ground Cable at Landing Gear must be connected			
----	---	--	--	--

3.2.3.

3.2.4. *Periodical inspection after every 100 flight hours*

Model :	S/N :	Registration :	Date of inspection :
	Hours flown :	No. of take-off :	

Event	Event description	Remark	Carried out by	Inspected by

## **4. OPERATION AND MAINTENANCE**

### **4.1. Outlines**

During operation and maintenance of the Samba XXL airplane is required to follow the instructions stated in following documents

- Operating and Maintenance Manual for Ultralight Airplane Samba XXL
- Flight Manual for Ultralight Airplane Samba XXL
- Engine Operator's Manual
- Additional documents supplied with instruments and equipment

The airworthiness and operational readiness of the airplane depends upon careful adherence to the recommended procedures

Periodical inspection intervals should be adapted to the operational conditions of your airplane abstractedly from the recommended intervals. Climate, manner of hanging, RWY conditions and other factors should be considered.

The procedures given in this manual suit average operational conditions of ultralight airplane.

### **4.2. Weight and Center of gravity position**

Never exceed the permitted Max. Take-off weight and GG range for any configuration of crew, fuel and baggage as shown in the Flight Manual.

#### **4.2.1. Empty weight determination**

The empty weight of on airplane includes all operating equipment that has a fixed location and is actually installed in the airplane. It includes the weight of the painted airplane, battery, avionics, full fluids ( oil, coolant, brake fluid ). The airplane is weighted without crew, fuel and baggage.

The following procedure is recommended:

1. Position the airplane on the scales
2. Level the airplane using rests ( reference plane is the frame below the canopy windows )
3. Check the configuration for weighting
4. Weigh the airplane, record values in the weight and Balance record.
5. Calculate the weight and C.G. position according to formula in the Weight and Balance Record.
6. Calculate the useful load range and vp-date the Record "Load Limits" in the cockpit.  
Record the new empty weight and permitted crew weight for fuelling and baggage weight.

#### **4.2.2. Operating C.G. range calculation**

On the basis of knowledge of arms and weights of items such a crew, fuel and baggage it is possible to calculate the operating C.G. position.

Center of Gravity Range  
Operating C.G. range 24-36%MAC

**OPERATING AND MAINTENANCE MANUAL FOR ULTRALIGHT AEROPLANE  
Samba XXL**

**4.3. Mechanism adjustments**

**4.3.1. Torque moments**

<b>Maximum permitted screw and nut torque moments strength class 5S</b>		
<b>Metric thread M</b>	<b>Torque moment M max (kpm)</b>	<b>Torque moment M max (Nm)</b>
4	0,17	1,67
5	0,35	3,45
6	0,6	5,9
8	1,5	14,7
10	3	28,4

OPERATING AND MAINTENANCE MANUAL FOR ULTRALIGHT AEROPLANE  
Samba XXL

4.3.2. Control Surface Deflections

Aileron

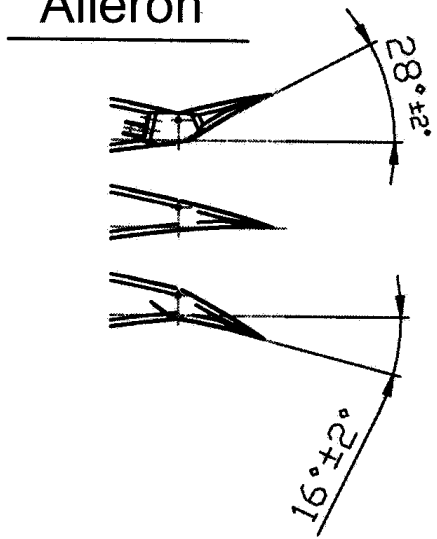

Rudder

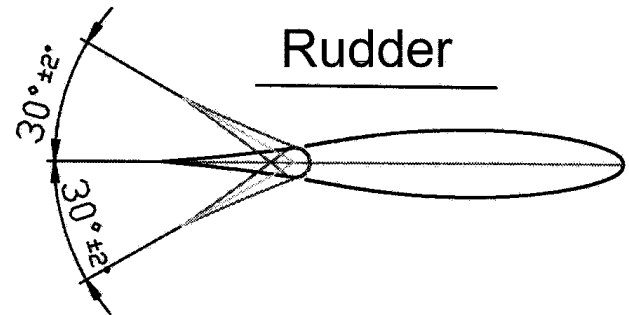

Flap

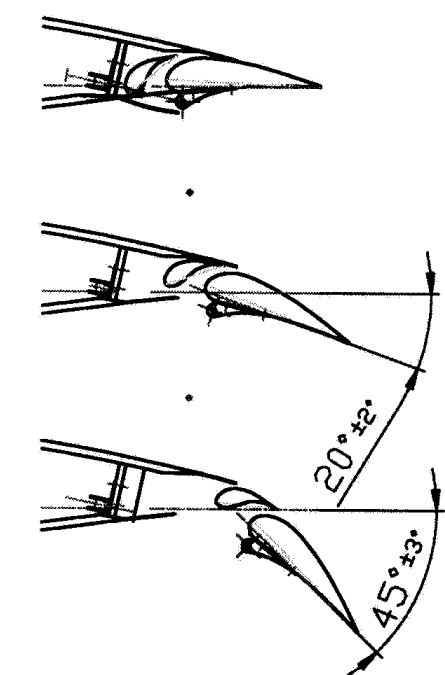

Elevator

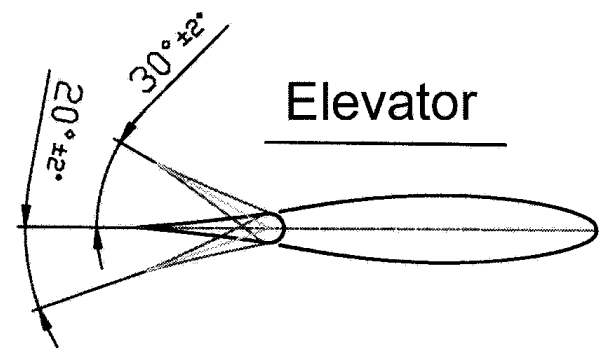



**OPERATING AND MAINTENANCE MANUAL FOR ULTRALIGHT AEROPLANE  
Samba XXL**

**4.4. Permissible tolerances ( plays)**

<b>System</b>	<b>Procedure to find a play</b>	<b>Procedure to remedy a play</b>	<b>Max. product. play</b>	<b>Max. operate play</b>
Ailerons control system	Block ailerons up the wing a move the control stick to the left and right	Check condition the bearings. Replace if needed	2	3
Elevator control system	Block the elevator up to the stabiliser, pull and push the control stick	Check condition the bearings. Replace if needed the bearings	2	3
Flaps control system	Extend the flaps and then handle the flap trailing edge near the flap root, move the trailing edge up/downward	Check condition the bearings. Replace if needed the bearings and flaps control system bushing	4	6
Wing-fuselage attachment	Move the wing tip to all directions and note play in wing suspensions	Put the washers on the rear pin to take up the axial clearance	0	0
HTU attachment	Move the stabiliser tip in all directions. Note a play of HTU at the stabiliser tip	Contact the airplane manufacturer for replacement of pins and reaming of bushings	0,5	1
Nose wheel landing gear	Push the rear part of fuselage down to lift the nose wheel, the move the nose wheel forward/rearward. Note play at the wheel axle	Replace sliding bearing, check and replace the wheel bearings if needed	1	5
Main landing gear	Lift the wing tip to the lift the main leg, then move the wheel forward/rearward. Note play of the wheel bearings.	Check conditions of bearings. Replace if needed	0	0

**OPERATING AND MAINTENANCE MANUAL FOR ULTRALIGHT AEROPLANE  
Samba XXL**

**4.5. Lubricating Chart**

*4.5.1. Recommended lubricants*

<b>Lubricating point</b>	<b>Lubricant</b>	<b>Lubricating point No.</b>
Control system levers, bearings, wing suspensions, HTU suspensions	Off-shelf neutral greases For example PM-LV 2-3	<b>1</b>
Nose wheel fork vertical axis	Off-shelf neutral greases For example PM-LV 2-3	
Aileron, flap, elevator and ruder hinges	MOLICA G plastic grease	<b>2</b>
Ruder pedal attachment, flaps control	Car engine oil	<b>3</b>

*4.5.2. Airframe lubrication fundamentals*

The lubrication chart supposes that there are some inaccessible joints of the control system inside the wing and fuselage with covered ball bearings which need not be lubricated during periodical inspection. Lubricate the swivel and sliding bearings per lubricating chart. The joints exposed to external conditions must be checked periodically and lubricated as is necessary during operation.

**OPERATING AND MAINTENANCE MANUAL FOR ULTRALIGHT AEROPLANE**  
**Samba XXL**

**4.6. Brake fluid refilling, brake system bleeding, brake pad clearance adjustment**

**4.6.1. Brake fluid refilling**

Add the SYNTOL HD 205 (Nom. 097 403) brake fluid (or equivalent) into the brake system master cylinder located at the pilots control stick. Remove the cap from the master cylinder to do it.

**4.6.2. Brake system bleeding**

1. Fill a syringe with brake fluid
2. Put the transparent brake hose (~ 300 mm length ) on the syringe outlet
3. Put the suitable pot below the Brake system master cylinder located at the control stick
4. Unscrew the Master cylinder cap
5. Loose the bleeding screw on the left wheel brake calliper
6. Put the transparent hose on the loosen left bleeding screw
7. Push/pull repeatedly the syringe lever to add brake fluid into the hydraulic cylinder and bleed it. Repeat until no air bubbles are drawn
8. Tighten the left bleeding screw
9. Proceed on the right wheel. Loosen the bleeding screw, put the hose on, repeatedly push/pull the syringe lever until no air bubbles flow into the brake system master cylinder located in the cockpit. Overflow brake fluid runs into the pot placed below the master cylinder or may be drawn by the syringe.
10. Add the brake fluid so that the level is 2 mm below the Master cylinder upper edge
11. Screw the Master cylinder cap
12. Check the system for function and leak

**4.6.3. Brake pad clearance adjustment**

You should take up the clearance of worn-out brake pads because the movement of the hydraulic cylinder is then short and brake system efficiency is going to be unsatisfactory. Measure the clearance using the feeler gauge. Insert the a thin sheet of required thickness between the hydraulic cylinder and brake pad to take out the clearance. Two holes for M5 screw must be drilled through that thin sheet.

**4.6.4. Brake pad replacement**

Unscrew the brake pads and replace by the new ones.  
Do not empty the brake fluid..

**4.7. The period of time to change the brake fluid**

The period of time to change the brake fluid, please follow the instructions of the producer of the fluid .

**OPERATING AND MAINTENANCE MANUAL FOR ULTRALIGHT AEROPLANE  
Samba XXL**

Ground handling

*4.7.1. Towing the airplane*

It is easy to tow the airplane a short distance by holding the blade root because the empty weight of this airplane is relatively low.

Suitable surfaces to hold the airplane airframe are the rear part of the fuselage before the fin and wings roots.

A tow bar may be used to tow the airplane for a long distance.

**CAUTION**

Avoid excessive pressure at the airplane airframe – especially at the wing tips, elevator, ruder, trim etc.

**CAUTION**

Handle the propeller by holding the blade root – never the blade tips! If starting the engine manually – always handle the propeller on a blade surface i.e. do not an edge.

*4.7.2. Parking the airplane*

It is advisable to park the airplane inside a hangar or eventually inside other weather proof space (such as garage) with a stable temperature, good ventilation, low humidity and dust-free Environment.

If necessary to tie-down the airplane when parking outside.

When the plane must be tied-down outdoors for extended periods, it is advisable to cover the cockpit canopy, and if possible, the entire airplane using the a suitable cover.

*4.7.3. Teeing-down*

The airplane is usually tied-down when parking outside a hangar. The tie-down is necessary to protect the airplane against possible damage caused by wing gusts.

Procedure:

1. Check: Fuel valve off, Circuit breakers and Master switch off, Switch box off.
2. Block the control stick up e.g. by means of safety harness or connect the control stick with rudder pedals by means of a suitable rope.
3. Shut all the ventilation windows
4. Close and lock cockpit
5. Tie-down the airplane to the ground by means of a mooring rope – wing tip with special sack, the nose wheel landing gear or the tail skid to the ground

**NOTE**

It is advisable to cover cockpit canopy, if possible the whole airplane, by means of a suitable covering material attached to the airframe for long term outside parking

*4.7.4. Jacking the airplane*

Because the empty weight of this airplane is relatively low it is easy to lift the airplane using two persons

First prepare two suitable jacks to support the airplane.

The airplane should be lifted by the following parts:

- Press down on the rear of the fuselage in front of the fin to lift the front and then support under the firewall
- To jack the rear of the fuselage grab the fuselage near the auxiliary tail skid, lift it upward and support
- To lift the wings, push on the wings lower surface at the main spar. Do not lift by the wing tips.

**OPERATING AND MAINTENANCE MANUAL FOR ULTRALIGHT AEROPLANE**  
**Samba XXL**

*4.7.5. Road transport*

The airplane may be transported in a suitable trailer. It is necessary to remove the wings before loading. The airplane and removed wings should be fastened down to ensure against a possible damage.

**OPERATING AND MAINTENANCE MANUAL FOR ULTRALIGHT AEROPLANE  
Samba XXL**

**4.8. *Cleaning and care***

**4.8.1. *Airplane care outlines***

Use mild detergents to clean the exterior surfaces. Oil spots on the surfaces (except the canopy!) may be cleaned with gasoline or strong detergents such as 409.

Upholstery covers can be removed from the cockpit, brushed or washed in lukewarm water with laundry detergent. Dry the upholstery before reinstalling.

**4.8.2. *External surfaces cleaning***

The external fiberglass surfaces of the airplane are protected with weather-proof paint. Wash the airplane surface with lukewarm water and car wash detergents. Then wash the airplane with water and sponge dry. It is recommended to protect painted external surfaces twice a year by applying a automotive type polish. Use only on a clean and dry surface, and polish with a soft flannel rag.

**CAUTION**

- Never wipe a dry surface – the surface may be scratched by dust and dirt
- Never apply any chemical solvents
- Repair a damaged painted surface (see par. 5.2)

**4.8.3. *Interior cleaning***

Keep in mind the following:

- Remove any loose objects from the cockpit
- Vacuum the interior and upholstery
- Wipe the upholstery using a rag with in lukewarm water and mild laundry detergent. Then dry or remove the seat upholstery and clean with lukewarm water upholstery cleaners. Dry thoroughly before reinstallation
- Clean the cockpit canopy interior surface (see par.4.10.4 below)

**4.8.4. *Cockpit canopy cleaning***

The canopy may be cleaned by washing it with lukewarm water and car or laundry type detergents. Use a clean, soft cloth. Then use a suitable polisher on the canopy such as Maguire's plastic polish.

**CAUTION**

- Never clean dry canopy
- Never apply gasoline or chemical solvents
- Cover the canopy with a cover sheet

#### **4.9. Airplane disassembly**

##### **4.9.1. Wing disassembly**

3 persons are needed to accomplish this task

Wing disassembly procedure:

1. Unlock the rear pins – slightly pull and turn the pins /90°
2. Unlock the main pin – turn it 180° and take out
3. Pull the right wing from the fuselage (disconnect the fuel tank hose and fuel quantity float sensor). The left wing must be held at this time!
4. Pull the left wing from fuselage

The position light wires must be disconnected if installed, also

##### **4.9.2. Wing assembly**

Follow the wing disassembly procedure in reverse order

**CAUTION**

Carefully shift the control system bells into the automatic grips of ailerons and flaps control system

##### **4.9.3. HTU disassembly**

1. Rematch the safety pin and unscrew the M8 screw
2. Pull the HTU rearward and lifted ( disconnected the position light /anti collision light if installed after HTU disassembly)
3. Remove the HTU

##### **4.9.4. HTU assembly**

Follow the HTU assembly procedure in reverse order

**CAUTION**

Carefully shift the elevator control bell into the groove at the automatic guiding of the HTU control

## **5. Repairs**

### **5.1. *Damage classification***

Various types of damage may occur during airplane operation and handling. It is important to correctly classify damage according to its character, size and especially, which part of airplane has been damaged.

The important parts are the engine, engine mount, propeller, wing spar center section of wing, stabilizer, landing gear legs and parts of the primary control system.

Minor damage may be repaired by the airplane operator / owner, but major structural damage should be repaired by replacement of damaged parts or repaired by an authorized service center.

Any damage and its repair should be recorded in the Log Books.

### **5.2. *Rudder control cables replacement***

Contact the airplane manufacturer for replacement procedure or an authorised Service Centre to replace the cables.

### **5.3. *Fibreglass fairing and cowlings repairs***

Cracks, breaks and permanent deformations are the most prevalent type of damage.

According to character of the damage the damage part should be cut out or sanded (bevel approx. 20x material thickness), any point of area to be repaired must be removed.

Put the first fibreglass cloth layer, then apply the resin L 285 mixed with the hardener H 286 (proportion of mixture 100:38) and continue as needed. The fibreglass cloth layers should have a short overlap.

After the resin has cured, sand the surface of repaired area, apply the polyester cement.

Sand the edges of repaired area (with 50-100 mm) using sand paper (grit size 400) to remove the old paint and prepare the area for painting.

Cover the place to be not painted and spray the repaired area using T 35 two component colour. Wet sand the area after paint curing using sand papers of 400, 800, 1200 grit size.

Apply polishing paste, use a soft cloth to polish the repaired area.



**6. Appendices**

- Weight and balance record.
- Control surfaces deflections record
- Flight test record
- Spare parts order